

General Description

Series RPL relief valves are pilot operated, ball-type relief valves. Their best application is a main system relief where smooth consistent performance is required.

Operation

The pilot section opens when inlet pressure on the RPL relief valve exceeds the valve setting. This pilot flow creates a pressure imbalance across the main section causing the valve to open. The pilot section closes once the inlet pressure drops below the valve setting. As a result, this re-seats the poppet in the main valve and closes it.

Features

- Compact, low profile design
- Pilot operated for smooth, stable operation
- High tensile, compacted graphite body

Specifications

Input Flow	225 LPM (60 GPM)
Operating Pressure SAE Ports NPTF Ports	350 Bar (5000 PSI) 138 Bar (2000 PSI)
Operating Temperature Range (Ambient)	Nitrile Seals: -40°C to +93°C (-40°F to +200°F)
Material	Body – High strength cast iron Poppet – Hardened and ground steel
Filtration	ISO Code 16/13 SAE Class 4 or better
Mounting Position	In-line; no restrictions

Ordering Information

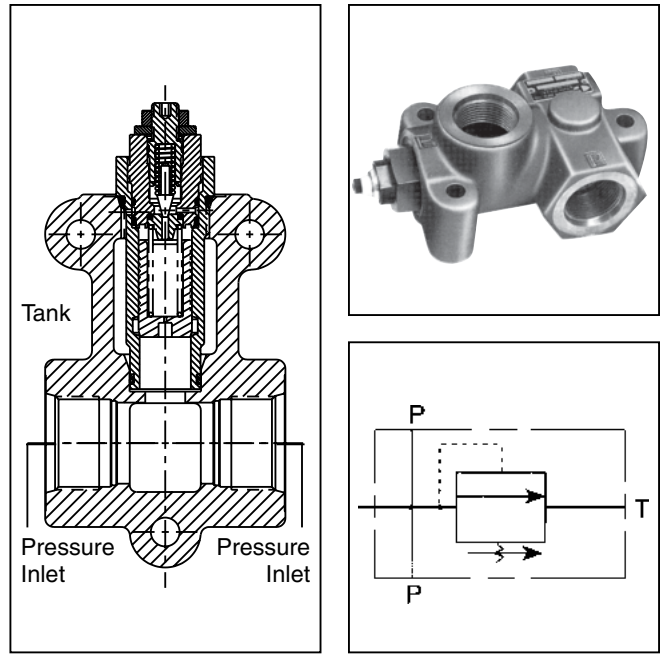
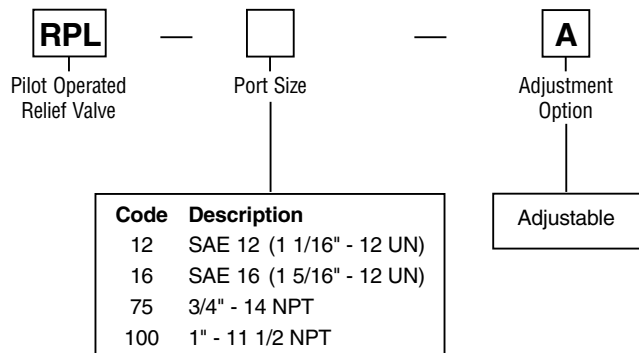

Performance Curve

Crack – 34 to 345 Bar (500 to 5000 PSI)

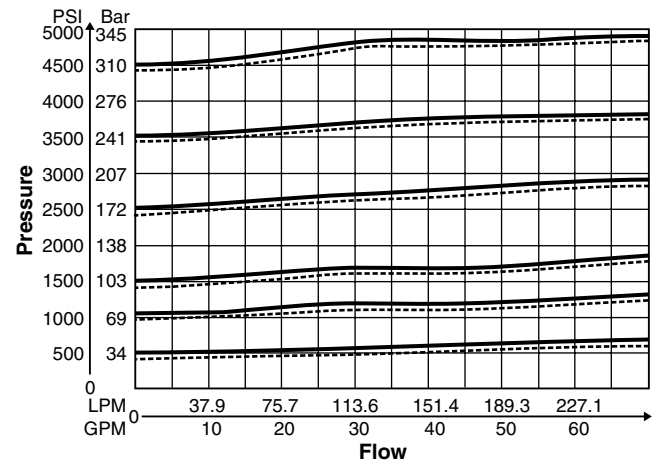

Service Parts

Relief Valve	RP60-A
External Seal – relief valve	3914N-9
Body Kit	
RPL-16	K-RPL-16
RPL-75	K-RPL-75
RPL-100	K-RPL-100
Relief Adjustment	1/4 turn = 200 PSI ±10%

Note: The body and the internal parts of the relief valve (including the spring) are non-service items

Inch equivalents for millimeter dimensions are shown in (**)

